

TTW 2500A

TTW 2500A F

TTW 2500P

TTW 2500P F



Spare Parts List

TIG Manual welding torch



4,035,850 TTW2500A F++ / UD / 4m
 4,035,851 TTW2500A F++ / UD / 8m
 4,035,852 TTW2500A F++ / UD / Le 4m
 4,035,853 TTW2500A F++ / UD / Le 8m
 4,035,854 TTW2500A F / F++ / UD / 4m
 4,035,855 TTW2500A F / F++ / UD / 8m

4,035,850,630 TTW2500P F++ / UD / 4m
 4,035,851,630 TTW2500P F++ / UD / 8m
 4,035,852,630 TTW2500P F++ / UD / Le 4m
 4,035,853,630 TTW2500P F++ / UD / Le 8m
 4,035,854,630 TTW2500P F / F++ / UD / 4m
 4,035,855,630 TTW2500P F / F++ / UD / 8m
 4,035,855,630 TTW2500P F / F++ / UD / 8m

4,035,881 TTW2500A F++ / 4m
 4,035,881,630 TTW2500P F++ / 4m
 4,035,882 TTW2500A F++ / 8m
 4,035,882,630 TTW2500P F++ / 8m

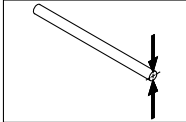
	Ø mm	Ø inch
	1,0-3,2	.039-.126





TTW 2500A, TTW 2500P

Ersatzteilliste / Spare parts list / Listes de pièces de rechange / Lista de repuestos / Lista de peças sobresselentes / Lista dei Ricambi

UP/DOWN

Option

UP/DOWN	Standard	TCS
 <p>44.0350.2173 4.070.816</p>	 <p>44.0350.2172 4.070.817</p>	 <p>42.0405.0569</p>

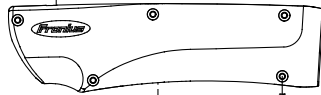

42.0405.0564 R/L
5x 42.0401.0936

Schutzschl. OG 18x1,25
44.0350.2568 4m / 13,1ft / 44.0350.2569 8m / 26,2ft

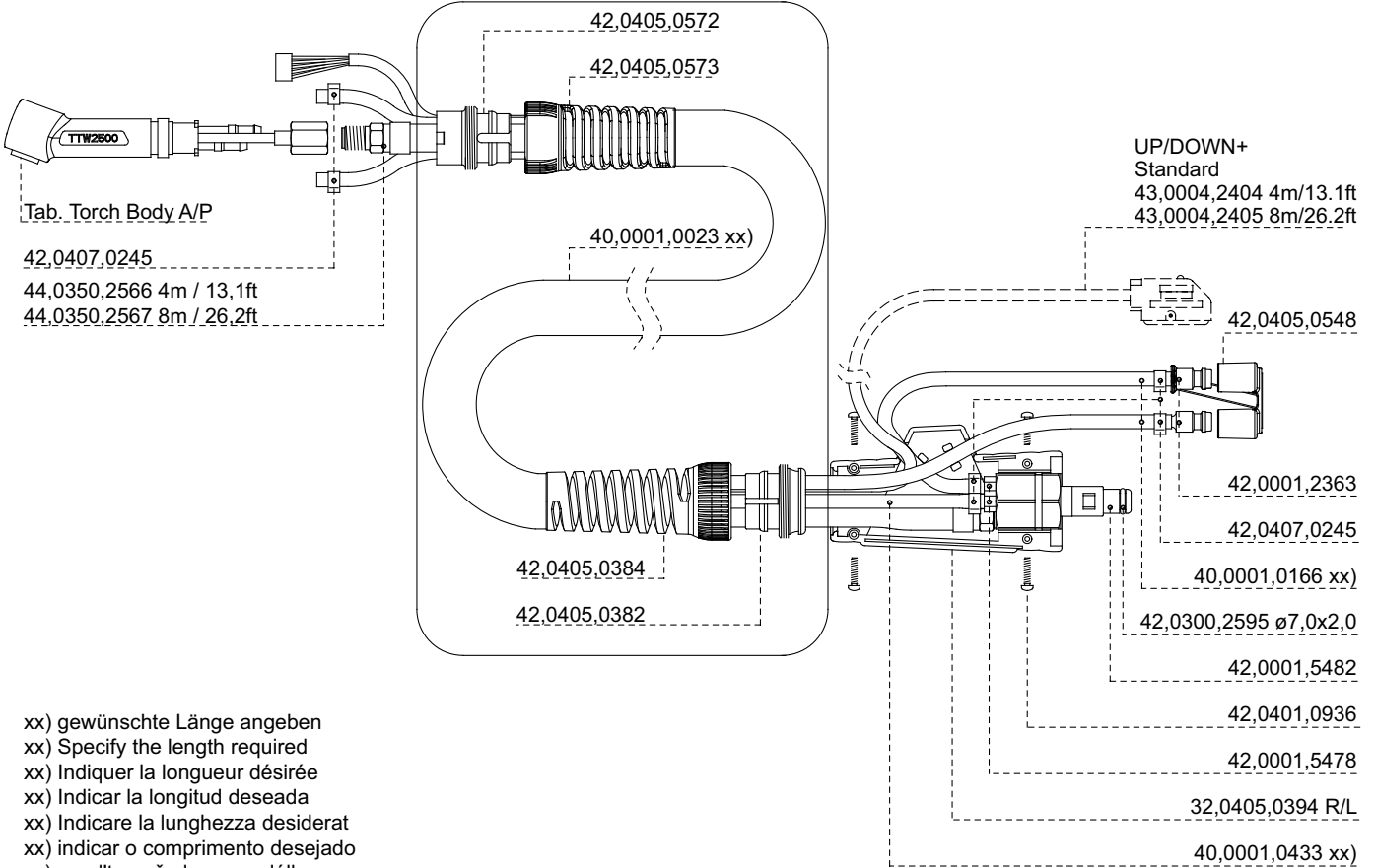

xx) gewünschte Länge angeben
xx) Specify the length required
xx) Indiquer la longueur désirée
xx) Indicar la longitud deseada
xx) Indicare la lunghezza desiderat
xx) indicar o comprimento desejado
xx) uved'te požadovanou délku

Leder / Leather / Cuir
44.0350.2570 4m / 13,1ft / 44.0350.2571 8m / 26,2ft

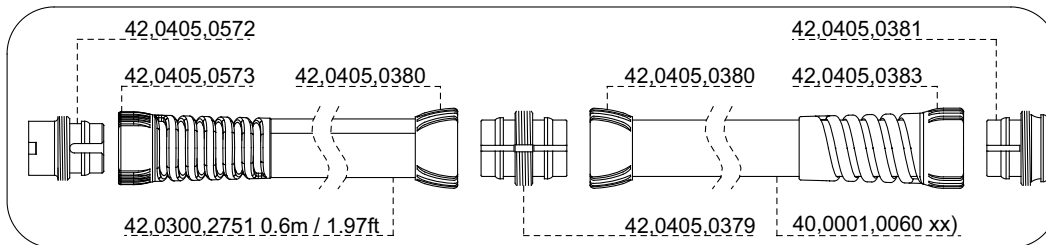

TTW 2500A, TTW 2500P

Ersatzteilliste / Spare parts list / Listes de pièces de rechange / Lista de repuestos / Lista de peças sobresselentes / Lista dei Ricambi

A-System

Part No. gas lens	Part No. clamping nut	Part No. collet	Part No. electrode WC20	Part No. electrode WP	Electrode Ø	
					Ø mm	Ø inch
44,0350,1500	42,0001,0692	42,0001,1148	42,0411,4012		1,0	.039
44,0350,1501	42,0001,0693	42,0001,1149	42,0411,4001	42,0411,4008	1,6	.063
44,0350,1460	42,0001,0694 x)	42,0001,1150 x)	42,0411,4002 x)	42,0411,4005	2,4	.094
44,0350,1461	42,0001,0695	42,0001,1151	42,0411,4003	42,0411,4006	3,2	.126

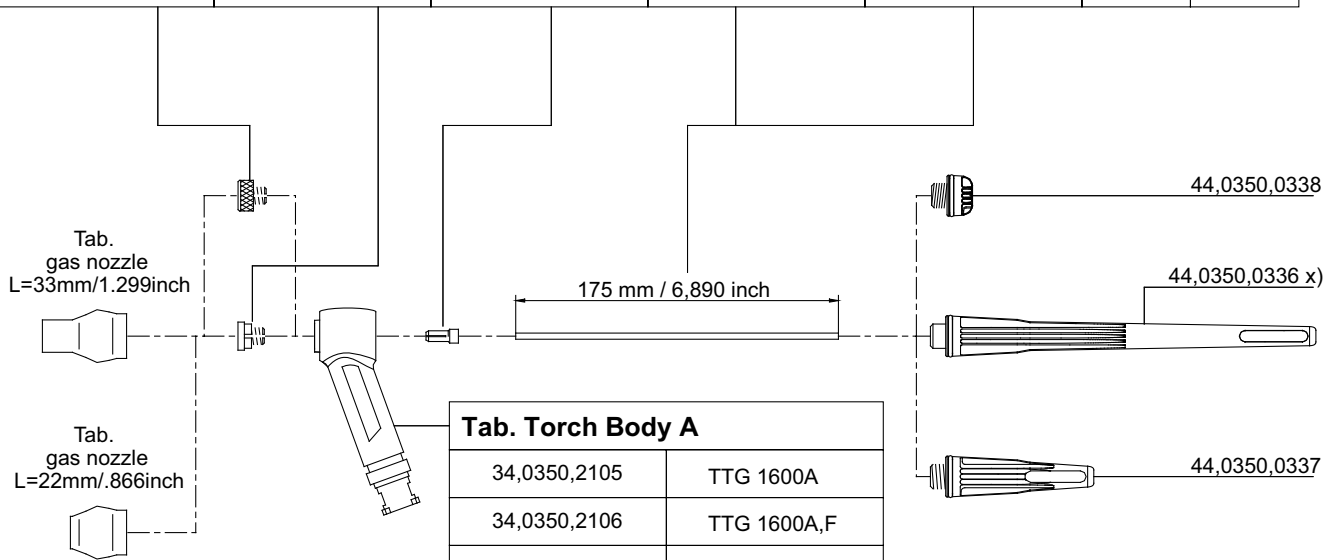

Tab. Torch Body A	
34,0350,2105	TTG 1600A
34,0350,2106	TTG 1600A,F
44,0350,2546	TTW 2500A
44,0350,2547	TTW 2500A,F
34,0350,2114	TTW 3000A
34,0350,2115	TTW 3000A,F
44,0350,2893	TTG 1200A
44,0350,2911	TTG 1200A,F

- x) Standardausrüstung
- x) standard equipment
- x) équipement standard
- x) equipamiento estándar
- x) accessori standard
- x) equipamento de série

gas nozzle ceramic plugable L=33mm/1.299inch	Part No.	gas nozzle ceramic plugable L=22mm/.866inch	Part No.	d1		d2	
				mm	inch	mm	inch
	42,0300,0820		42,0300,0816	6,35	.250	20,8	.819
	42,0300,0821		42,0300,0817	8,0	.315	20,8	.819
	42,0300,0822 x)		42,0300,0818	9,5	.374	20,8	.819
	42,0300,0823		42,0300,0819	11,1	.437	20,8	.819



Wearing parts TTG 1600 / 1200 TTW 2500 / 3000 A F

Ersatzteilliste / Spare parts list / Listes de pièces de rechange / Lista de repuestos / Lista de peças sobresselentes / Lista dei Ricambi

P-System

STANDARD

Part No. collet body	Part No. head shield	Part No. collet	Part No. electrode WC20	Part No. electrode WP	Electrode Ø	
					Ø mm	Ø inch
42,0001,2827	42,0100,0391 x)	42,0001,3000	42,0411,4012		1,0	.039
42,0001,0260		42,0001,2571	42,0411,4001	42,0411,4008	1,6	.063
42,0001,0261 x)		42,0001,2572 x)	42,0411,4002 x)	42,0411,4005	2,4	.094
42,0001,0262		42,0001,2573	42,0411,4003	42,0411,4006	3,2	.126

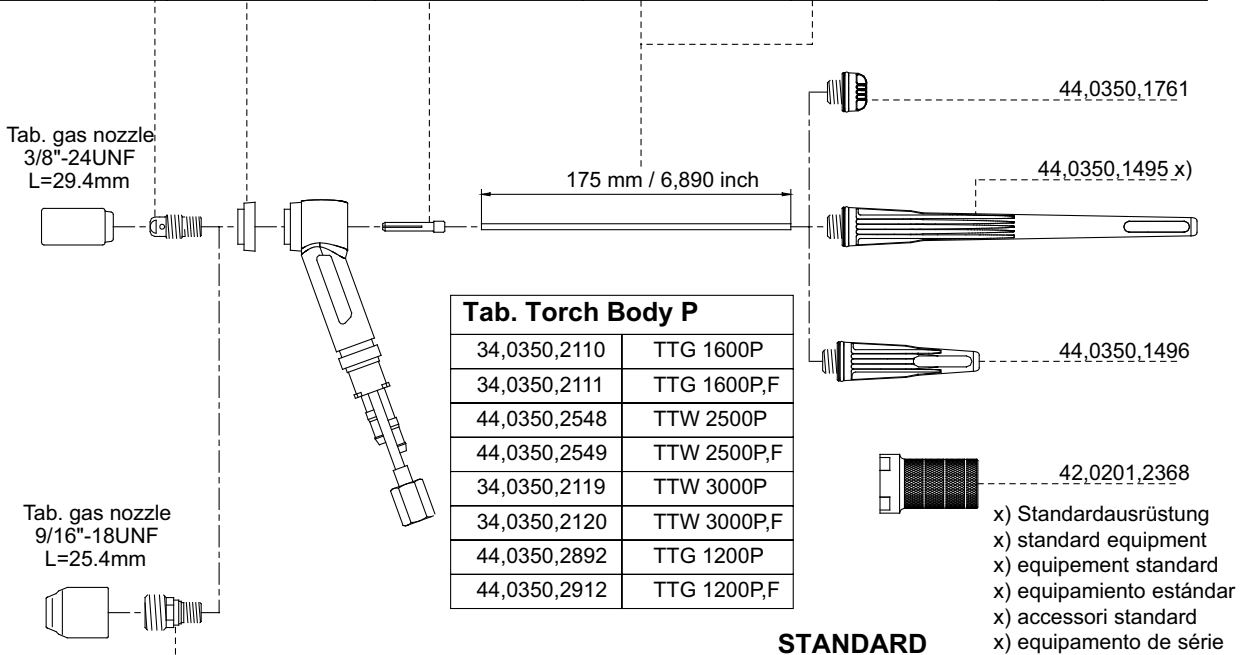

Tab. Torch Body P	
34,0350,2110	TTG 1600P
34,0350,2111	TTG 1600P,F
44,0350,2548	TTW 2500P
44,0350,2549	TTW 2500P,F
34,0350,2119	TTW 3000P
34,0350,2120	TTW 3000P,F
44,0350,2892	TTG 1200P
44,0350,2912	TTG 1200P,F

STANDARD

gas nozzle ceramic screwable 3/8"-24UNF L=29.4mm / 1.157inch	d1		d2		Part No.
	mm	inch	mm	inch	
	6,3	.248	14,2	.559	42,0300,0105
	8,0	.315	14,2	.559	42,0300,0106
	9,5	.374	14,2	.559	42,0300,0107 x)
	11,2	.441	16,2	.638	42,0300,0108
	12,7	.500	17,6	.693	42,0300,0109
	16,0	.630	20,5	.807	42,0300,0110

GAS LENS STANDARD

Electrode ø	Part No. gas lens	
	mm	inch
1,0	.039	42,0001,1343
1,6	.063	42,0001,1344
2,4	.094	42,0001,1345
3,2	.126	42,0001,1346

GAS LENS STANDARD

gas nozzle ceramic screwable 9/16"-18UNF L=25.5mm / 1.004inch	d3		d4		Part No.
	mm	inch	mm	inch	
	6,3	.248	20,0	.787	42,0300,0982
	8,0	.315	20,0	.787	42,0300,0983
	9,5	.374	20,0	.787	42,0300,0984
	11,2	.441	20,0	.787	42,0300,2007
	12,5	.492	20,0	.787	42,0300,2008



Wearing parts TTG 1600 / 1200 TTW 2500 / 3000 P F

Ersatzteilliste / Spare parts list / Listes de pièces de rechange / Lista de repuestos / Lista de peças sobresselentes / Lista dei Ricambi

P-System

GAS LENS LARGE

Part No. collet body	Part No. head shield	Part No. collet	Part No. electrode WC20	Part No. electrode WP	Electrode Ø	
					Ø mm	Ø inch
42,0001,3010	42,0100,0407	42,0001,2826	42,0411,4012		1,0	.039
42,0001,3011		42,0001,3001	42,0411,4001	42,0411,4008	1,6	.063
42,0001,3012		42,0001,3008	42,0411,4002	42,0411,4005	2,4	.094
42,0001,3013		42,0001,3009	42,0411,4003	42,0411,4006	3,2	.126

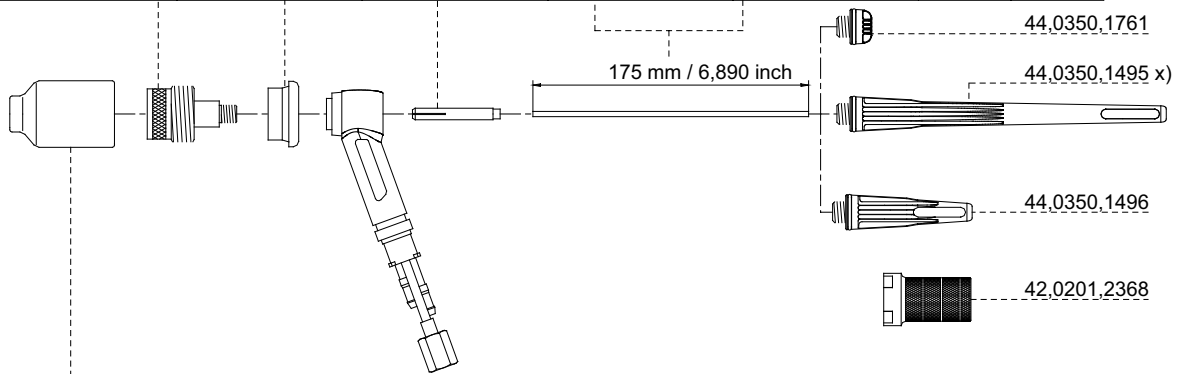

gas nozzle ceramic screwable 1"-16G L=48mm / 1.890inch	d5		d6		Part No.
	mm	inch	mm	inch	
	9,5	.248	30,3	1.193	42,0300,2247
	12,5	.315	30,3	1.193	42,0300,2248
	16,0	.630	31,0	1.220	42,0300,2249
	19,0	.748	31,0	1.220	42,0300,2250

Tab. Torch Body P	
34,0350,2110	TTG 1600P
34,0350,2111	TTG 1600P,F
44,0350,2548	TTW 2500P
44,0350,2549	TTW 2500P,F
34,0350,2119	TTW 3000P
34,0350,2120	TTW 3000P,F
44,0350,2892	TTG 1200P
44,0350,2912	TTG 1200P,F

GAS LENS SMALL

Part No. collet body	Part No. head shield	Part No. collet	Part No. electrode WC20	Part No. electrode WP	Electrode Ø	
					Ø mm	Ø inch
44,0350,1489	42,0100,0388 long	42,0001,3002	42,0411,4012		1,0	.039
44,0350,1490		42,0001,3003	42,0411,4001	42,0411,4008	1,6	.063
44,0350,1491	42,0100,0387 x)	42,0001,3004	42,0411,4002	42,0411,4005	2,4	.094

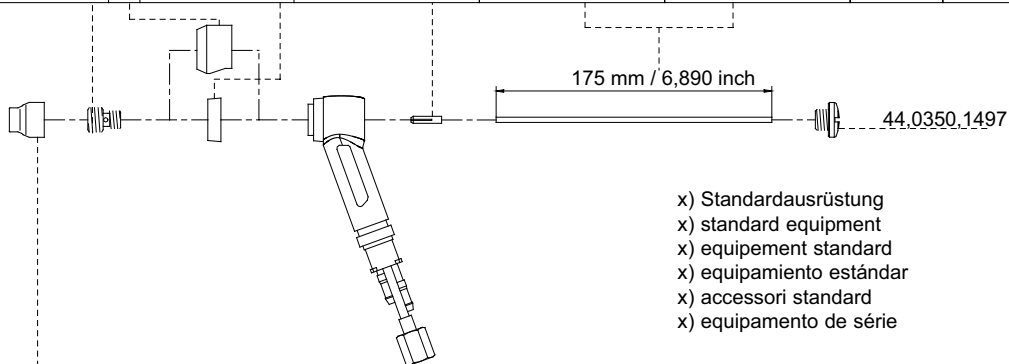

- x) Standardausrüstung
- x) standard equipment
- x) équipement standard
- x) equipamiento estándar
- x) accessori standard
- x) equipamento de série

gas nozzle ceramic screwable 7/16"-20UNF L=16,5mm / .650inch	d7		d8		Part No.
	mm	inch	mm	inch	
	6,5	.256	16,0	.630	42,0300,2244
	7,8	.307	16,0	.630	42,0300,2245
	9,5	.374	16,0	.630	42,0300,2246



Wearing parts TTG 1600 / 1200 TTW 2500 / 3000 P F

Ersatzteilliste / Spare parts list / Listes de pièces de rechange / Lista de repuestos / Lista de peças sobresselentes / Lista dei Ricambi



FRONIUS INTERNATIONAL GMBH

Froniusplatz 1, A-4600 Wels, Austria
Tel: +43 (0)7242 241-0, Fax: +43 (0)7242 241-3940
E-Mail: sales@fronius.com
www.fronius.com

www.fronius.com/addresses

Under <http://www.fronius.com/addresses> you will find all addresses
of our Sales & service partners and Locations.